

Domestic/Commercial Heat Recovery Units

The Windsor Range

MANHR100R/100RS



Features & Benefits

- Controls condensation and odours - saves energy.
- Eliminates mould growth.
- 70% Heat Recovery.
- Extremely quiet operation.

Technical Details

Model No.	Product type
MANHR100R	Std Heat Recovery Unit Top Access
MANHR100RS	Std Heat Recovery Unit Bottom Access
MANHR1345	Boost Switch

Performance

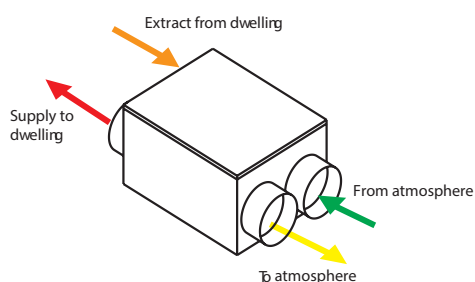

		HR100R	HR100RS
Weight	Kg	5.6	5.6
Extract Performance	Boost	19 (70)	19 (70)
	Trickle	11 (41)	11 (41)
Intake Performance m³/hr	Boost	70	70
	Trickle	30	30
Watts	Trickle	19	19
Sound dB(A) at 3m	Boost	30	30
	Trickle	20	20

Dimensions

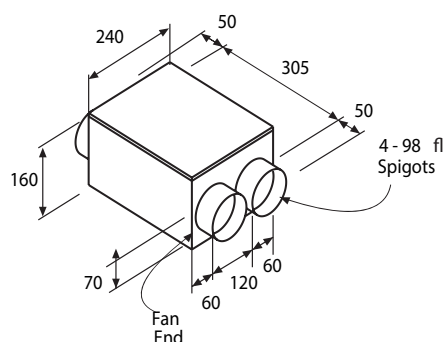

*For maximum controllability use this controller

ERP Out of Scope

