

The Windsor Range

Domestic/Commercial Heat Recovery Units

MANHR200



Features & Benefits

- Single room heat recovery ventilation unit for kitchens/ utilities room.
- Meets building regulations for kitchens and utility rooms for system 1 intermittent extract and for constant ventilation as per system 4 requirement.
- 3 speed motor.
- Integral washable filter.
- Up to 75% heat recovery.
- Saves energy -controls condensation.
- Extremely quiet.

Technical Details

Model No.

MANHR200WK

MANHR200CON

Product type

Std Kitchen Heat Recovery Unit

Electronic Controller*

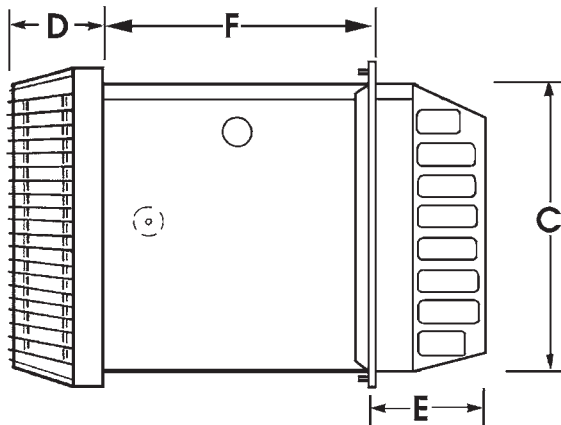
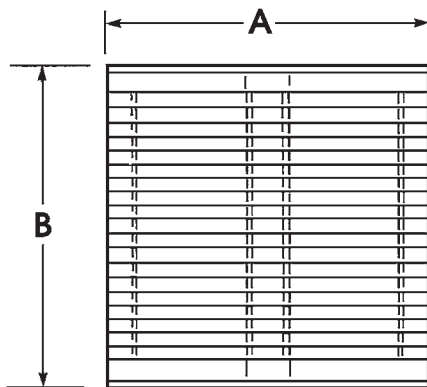

Performance

	Speed 1	Speed 2	Speed 3
Extract Performance m³/h	60	110	220
Intake Performance m³/h	50	100	200
Watts	25	60	140
% Heat Recovery	75	70	65
Sound dB(A) at 3m	19	33	46

Dimensions:

A	B	C	D	E	F	Weight
270	270	245	85	68mn	335max	9.7kg

*For maximum controllability use this controller

